



60

HB TYPE

齒輪軸(P)系列 GEAR TYPE

1.8°

正減速比

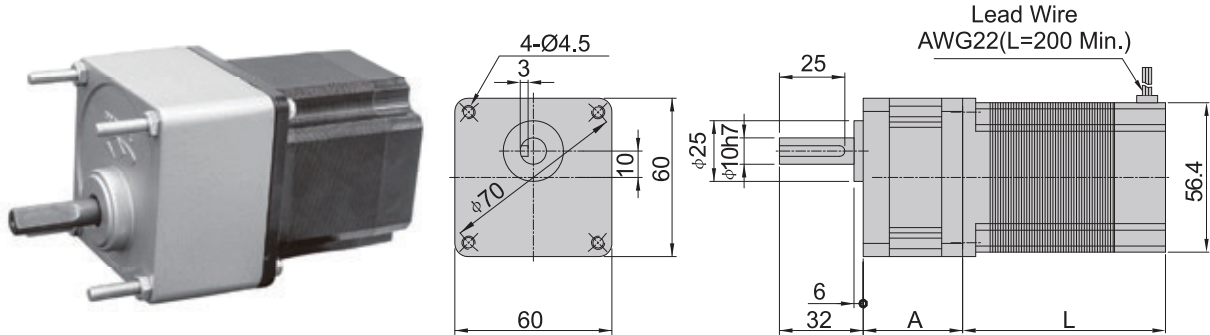

形式 Type number	基本步級角 Step Angle Deg.	額定電壓 Rated Voltage V/Phase	額定電流 Rated Current A/Phase	線圈阻抗 Winding Resistance Ω/Phase	線圈感抗 Inductance mH/Phase	激磁最大 靜止力矩 Holding Torque N·m(kgf·cm)	馬達長度L Motor Length mm	轉子慣量 Rotor Inertia x10 ⁻⁷ kg·m ²	質量 Mass kg
EXMK266-02GA-P	1.8	3.6	2	1.8	3.2	0.8(8)	55	280	0.7
EXMK268-02GA-P	1.8	4.5	2	2.25	3.8	1.3(13)	77.5	480	1

G-2N□-K10規格表

減速比	5	9	10	25	30	50
容許轉矩 N·m(kgcm)	2.5(25)					
容許推力載重 N(kg)	40(4)					
容許懸吊載重 N(kg)	100(10)					
尺寸A mm	36					

結線圖 WIRING DIAGRAM

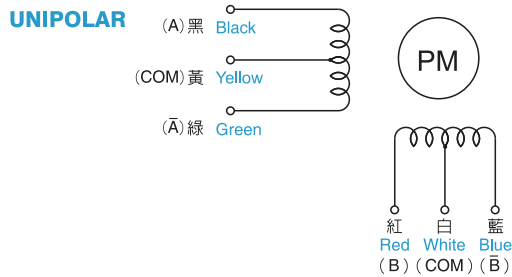

回轉方向：由出力軸目視之正轉方向
CW rotation from output shaft end.

Step	黑 Black	紅 Red	綠 Green	藍 Blue	黃 Yellow	白 White
0	ON	ON			COM	COM
1		ON	ON		COM	COM
2			ON	ON	COM	COM
3	ON			ON	COM	COM
0	ON	ON			COM	COM