

85

HB TYPE

附煞車 BRAKE TYPE

1.8°

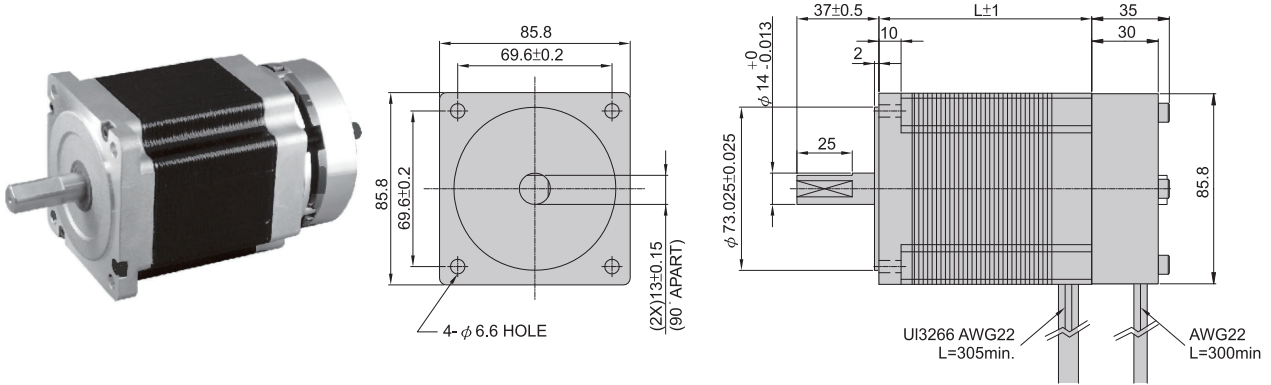

形式 Type number	基本步級角 Step Angle Deg.	額定電壓 Rated Voltage V/Phase	額定電流 Rated Current A/Phase	線圈阻抗 Winding Resistance Ω/Phase	線圈感抗 Inductance mH/Phase	激磁最大 靜止力矩 Holding Torque N-m(kgf·cm)	馬達長度L Motor Length mm	轉子慣量 Rotor Inertia x10 ⁻⁷ kg·m ²	重量 Weigh g
EXMK296-02M	1.8	4.4	2	2.2	8	2.2(22)	66	1400	1750
EXMK296-03M	1.8	3	3	1	4	2.2(22)	66	1400	1750
EXMK296-04M	1.8	2	4.5	0.48	1.7	2.2(22)	66	1400	1750
EXMK299-02M	1.8	6.4	2	3.2	20	4.4(44)	96	2700	2800
EXMK299-03M	1.8	4.2	3	1.4	6.6	4.4(44)	96	2700	2800
EXMK299-04M	1.8	2.8	4.5	0.66	3	4.4(44)	96	2700	2800
EXMK2913-02M	1.8	7.6	2	3.8	2.5	6.6(66)	126	4000	3930
EXMK2913-04M	1.8	3.8	4	0.95	5.5	6.6(66)	126	4000	3930

- 使用周圍溫度 ———— -20~+50°C
Operating temperature range
- 絕緣阻抗 ———— 100MΩ Min(at DC500V)
Insulation resistance
- 絕緣耐壓 ———— AC500V(1min)
Dielectric strength
- 軸心平行方向移動量 — 0.075mm Max. (With 1kg Load)
End play

※注 意:馬達表面請保持在90°C以下
※NOTE: Do not allow the surface temperature of the motor case to rise above 90°C during operation.

煞車規格

- 動作原理:斷電煞車(無激磁煞車)
- 額定電壓:DC24V
- 入力容量:13W
- 線圈電流:0.542A
- 線圈阻抗:44.3Ω
- 靜摩擦扭力:20kg.cm

結線圖 WIRING DIAGRAM

UNIPOLAR

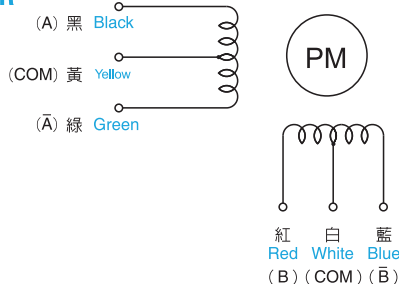

回轉方向:由出力軸目視之正轉方向
CW rotation from output shaft end.

Step	黑 Black	紅 Red	綠 Green	藍 Blue	黃 Yellow	白 White
0	ON	ON			COM	COM
1		ON	ON		COM	COM
2			ON	ON	COM	COM
3	ON			ON	COM	COM
0	ON	ON			COM	COM