

# 85 0.72° HB

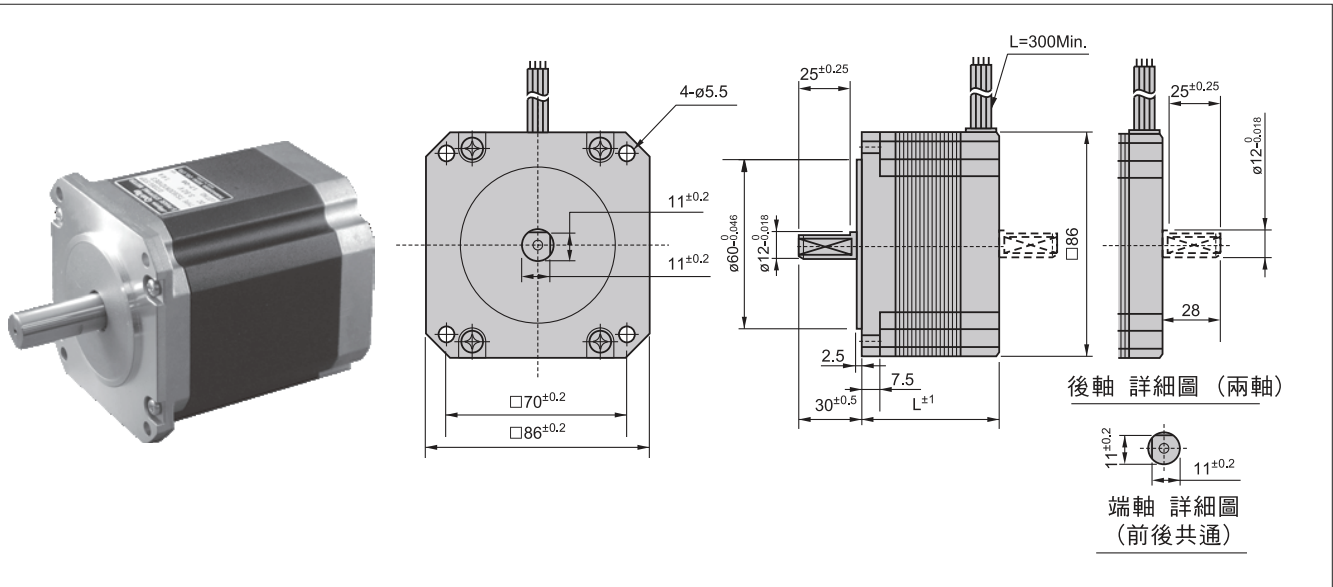

形式 Type number		額定電壓 Rated Voltage	額定電流 Rated Current	線圈阻抗 Winding Resistance	激磁最大 靜止力矩	馬達長度L Motor Length	轉子慣量 Rotor Inertia	質量 Mass	
單軸 Single Shaft	兩軸 Double Shaft	V/Phase	A/Phase	Ω/Phase	N-m(kgf·cm)	mm	g·cm <sup>2</sup>	g	
TS3630N1E1	TS3630N21E1	2.46	1.4	1.76	2.1(21)	64.5	900	1800	
TS3630N1E2	TS3630N21E2	2.1	2.8	0.57	2.1(21)	64.5	900	1800	
TS3630N2E3	TS3630N22E3	3.82	1.4	2.73	4.1(41)	96.5	2000	3000	(註1)
TS3630N2E4	TS3630N22E4	1.88	2.8	0.67	4.1(41)	96.5	2000	3000	
TS3630N1315E9		4.76	1.4	3.4	6.3(63)	126.5	3000	4000	(註2)
TS3630N3E5	TS3630N23E5	2.38	2.8	0.85	6.3(63)	126.5	3000	4000	

註1:軸心 Ø 14的品名為TS3630N1210E3(單軸)

註2:軸心 Ø 14mm(單軸)

- 使用周圍溫度 ———— -20~+50°C  
Operating temperature range
- 絕緣阻抗 ———— 100MΩ Min( at DC500V)  
Insulation resistance
- 絕緣耐壓 ———— AC500V(1min)  
Dielectric strength
- 軸心平行方向移動量 — 0.075mm Max.at the load 9.8N(1kgf)  
End play
- 軸心垂直方向移動量 — 0.025mm Max.at the load 4.9N(0.5kgf)  
Radial play
- 容許溫度上昇 ———— 80deg Max(Rasistance method)  
Permissible temperature rise

## 結線圖

### Wiring diagram

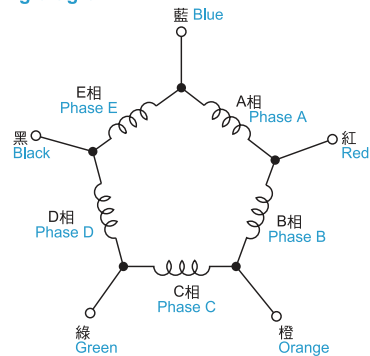

## 激磁順序 Exciting sequence

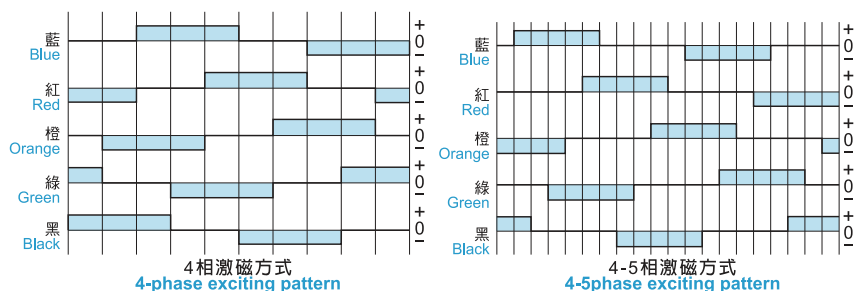

※注意:馬達表面請保持在90°C以下

※NOTE:Do not allow the surface temperature of the motor case to rise above 90°C during operation