

# 60 0.72° HB

## 附煞車 BRAKE TYPE

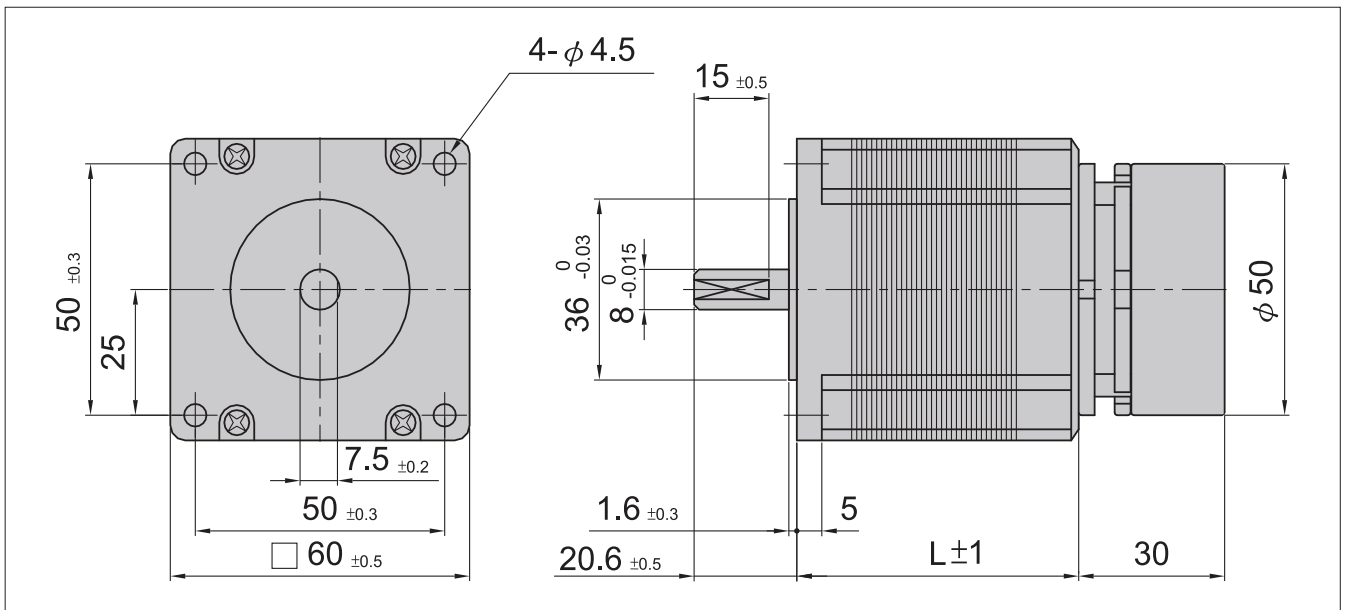

形式 Type number	額定電壓 Rated Voltage V/Phase	額定電流 Rated Current A/Phase	線圈阻抗 Winding Resistance Ω/Phase	激磁最大 靜止力矩 Holding Torque N-m(kgf·cm)	馬達長度L Motor Length mm	轉子慣量 Rotor Inertia g·cm <sup>2</sup>	質量 Mass g
K564-M	1.12	1.4	0.8	0.45(4.5)	48.5	175	500
K566-M	1.54	1.4	1.1	0.8(8)	56.5	220	700
K569-M	2.52	1.4	1.8	1.5(15)	86.5	440	1200

- 使用周圍溫度 ———— -20~+50°C  
Operating temperature range
- 絕緣阻抗 ———— 100MΩ Min(at DC500V)  
Insulation resistance
- 絕緣耐壓 ———— AC500V(1min)  
Dielectric strength
- 軸心平行方向移動量 — 0.075mm Max.at the load 9.8N(1kgf)  
End play
- 軸心垂直方向移動量 — 0.025mm Max.at the load 4.9N(0.5kgf)  
Radial play
- 容許溫度上昇 ———— 80deg Max(Rasistance method)  
Permissible temperature rise

※注意:馬達表面請保持在90°C以下  
 ※NOTE: Do not allow the surface temperature of the motor case to rise above 90°C during operation.

### 煞車規格

- 動作原理:斷電煞車(無激磁煞車)
- 額定電壓:DC24V
- 入力容量:7W
- 線圈電流:0.292A
- 線圈阻抗:82.3Ω
- 靜摩擦扭力:5kg.cm

### 結線圖

#### Wiring diagram

