

# 56

1.8°

HB TYPE

附煞車  
BRAKE TYPE

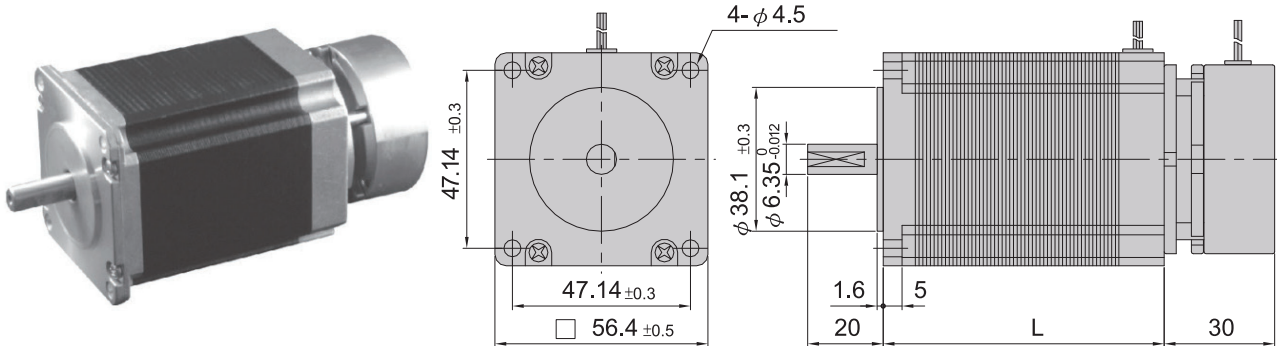

形式 Type number	基本步級角 Step Angle	額定電壓 Rated Voltage	額定電流 Rated Current	線圈阻抗 Winding Resistance	線圈感抗 Inductance	激磁最大 靜止力矩 Holding Torque	馬達長度L Motor Length	轉子慣量 Rotor Inertia	質量 Mass	結線 Winding Type
	Deg.	V/Phase	A/Phase	Ω/Phase	mH/Phase	N-m(kgf·cm)	mm	x10 <sup>-7</sup> kg·m <sup>2</sup>	kg	
K264-02M	1.8	2.8	2	1.4	1.4	0.39(3.9)	39	120	0.75	2
K266-02M	1.8	4.5	2	1.8	2.5	0.9(9)	54	260	1	2
K268-02M	1.8	4.5	2	2.25	3.6	1.35(13.5)	76	430	1.3	2
K2610-05M	1.8	2.2	5	0.44	1.4	2(20)	84	520	1.6	1

- 使用周圍溫度 ———— -20~+50 °C  
Operating temperature range
- 絕緣阻抗 ———— 100MΩ Min(at DC500V)  
Insulation resistance
- 絕緣耐壓 ———— AC500V(1min)  
Dielectric strength
- 軸心平行方向移動量 — 0.075mm Max. (With 1kg Load)  
End play

※注意:馬達表面請保持在90°C以下  
※NOTE: Do not allow the surface temperature of the motor case to rise above 90 °C during operation.

## 煞車規格

- 動作原理:斷電煞車(無激磁煞車)
- 額定電壓:DC24V
- 入力容量:7W
- 線圈電流:0.292A
- 線圈阻抗:82.3Ω
- 靜摩擦扭力:5kg·cm

## 結線圖

### WIRING DIAGRAM

#### TYPE 1 BIPOLAR

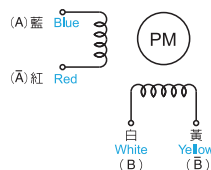

#### TYPE 2 UNIPOLAR

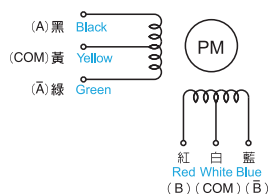

回轉方向:由出力軸目視之正轉方向  
CW rotation from output shaft end.

Step	藍 Blue	白 White	紅 Red	黃 Yellow
0	+	-	-	+
1	+	+	-	-
2	-	+	+	-
3	-	-	+	+
0	+	-	-	+

回轉方向:由出力軸目視之正轉方向  
CW rotation from output shaft end.

Step	黑 Black	紅 Red	綠 Green	藍 Blue	黃 Yellow	白 White
0	ON	ON			COM	COM
1		ON	ON		COM	COM
2			ON	ON	COM	COM
3	ON			ON	COM	COM
0	ON	ON			COM	COM