

# 28

HB TYPE

高扭力 · 低振動

1.8°

High torque

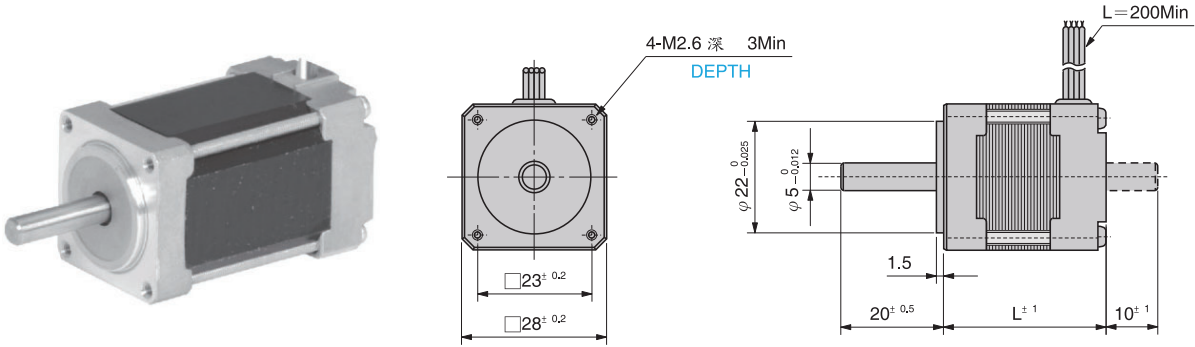

形式 Type number		基本步級角 Step Angle Deg.	額定電壓 Rated Voltage V/Phase	額定電流 Rated Current A/Phase	線圈阻抗 Winding Resistance Ω/Phase	線圈感抗 Inductance mH/Phase	激磁最大 靜止力矩 Holding Torque N·m(kgf·cm)	馬達長度L Motor Length mm	轉子慣量 Rotor Inertia x10 <sup>-7</sup> ·kg·m <sup>2</sup>	質量 Mass g
單軸 Single Shaft	兩軸 Double Shaft									
TS3641N1E1	TS3641N11E1	1.8	1.05	1.5	0.7	0.3	0.04(0.4)	33.5	8	150
TS3641N1E2	TS3641N11E2	1.8	2.6	0.95	2.7	1.2	0.06(0.6)	33.5	8	150
TS3641N2E3	TS3641N12E3	1.8	1.4	1.4	1.0	0.55	0.08(0.8)	47.5	18	180

- 使用周圍溫度 ———— -20~+50°C  
Operating temperature range
- 絕緣阻抗 ———— 100MΩ Min(at DC500V)  
Insulation resistance
- 絕緣耐壓 ———— AC500V(1min)  
Dielectric strength
- 軸心平行方向移動量 — 0.075mm Max. at the load  
End play

- 軸心垂直方向移動量 — 0.025mm Max. at the load 4.9N(0.5kgf)  
Radial play
- 容許溫度上昇 ———— 80deg Max(Rasistance method)  
Permissible temperature rise

※注意：馬達表面請保持在90°C以下  
※NOTE: Do not allow the surface temperature of the motor case to rise above 90°C during operation.

## 結線圖 WIRING DIAGRAM

### UNIPOLAR

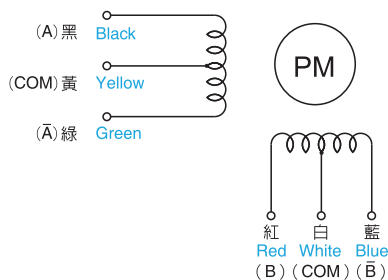

回轉方向：由出力軸目視之正轉方向  
CW rotation from output shaft end.

Step	黑 Black	紅 Red	綠 Green	藍 Blue	黃 Yellow	白 White
0	ON	ON			COM	COM
1		ON	ON		COM	COM
2			ON	ON	COM	COM
3	ON			ON	COM	COM
0	ON	ON			COM	COM