

20mm (SIZE 08) HB TYPE

1.8°

RoHS對應
RoHS compliant products.

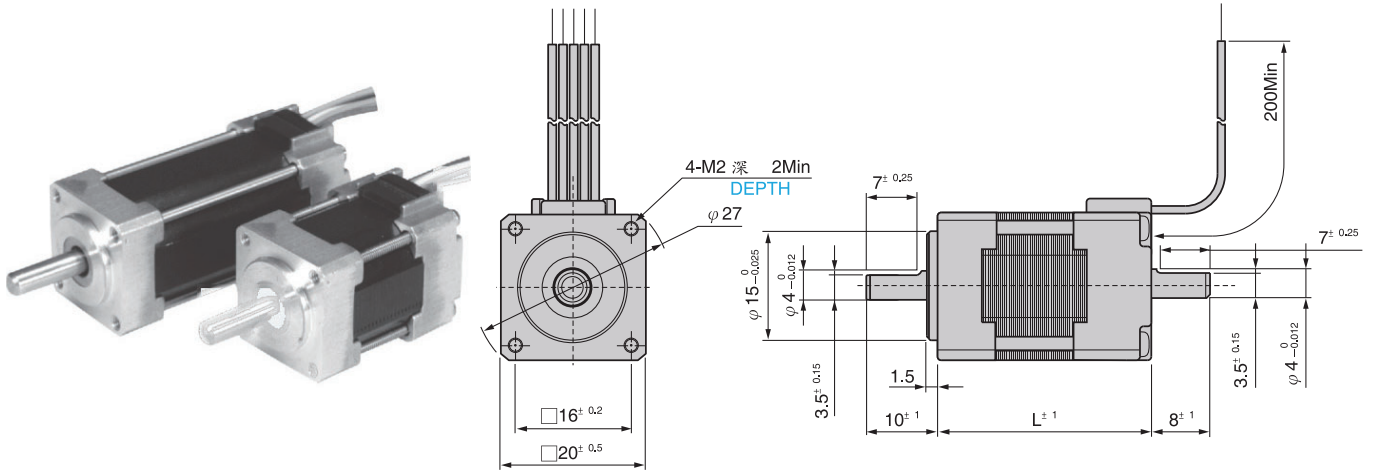

形式 Type number		基本步級角 Step Angle Deg.	額定電壓 Rated Voltage V/Phase	額定電流 Rated Current A/Phase	線圈阻抗 Winding Resistance Ω/Phase	線圈感抗 Inductance mH/Phase	激磁最大 靜止力矩 Holding Torque N·m(kgf·cm)	馬達長度L Motor Length mm	轉子慣量 Rotor Inertia x10 ⁻⁷ kg·m ²	質量 Mass g	結線 Winding Type
單軸 Single Shaft	兩軸 Double Shaft										
TS3692N1	TS3692N11	1.8	3.5	0.35	10	2.4	0.013(0.13)	30	1.9	50	TYPE 2
TS3692N41	TS3692N51	1.8	3	0.35	8.5	3.4	0.017(0.17)	30	1.9	50	TYPE 1
TS3692N2	TS3692N12	1.8	7	0.35	20	4.6	0.024(0.24)	46.5	4	80	TYPE 2
TS3692N42	TS3692N52	1.8	5.6	0.35	16	7	0.032(0.32)	46.5	4	80	TYPE 1

結線圖 WIRING DIAGRAM

TYPE 1 BIPOLAR

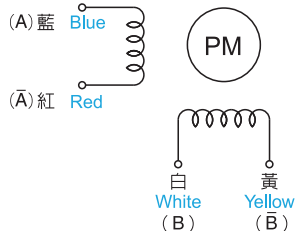

TYPE 2 UNIPOLAR

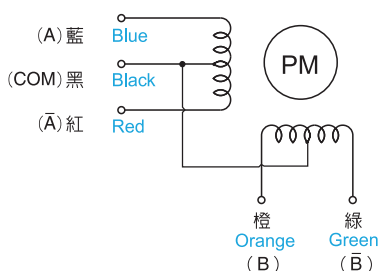

回轉方向：由出力軸目視之正轉方向

CW rotation from output shaft end

Step	藍 Blue	白 White	紅 Red	黃 Yellow
0	+	-	-	+
1	+	+	-	-
2	-	+	+	-
3	-	-	+	+
0	+	-	-	+

回轉方向：由出力軸目視之正轉方向

CW rotation from output shaft end.

Step	藍 Blue	橙 Orange	紅 Red	綠 Green	黑 Black
0	ON	ON			+V
1		ON	ON		+V
2			ON	ON	+V
3	ON			ON	+V
0	ON	ON			+V