

一般防塵等級

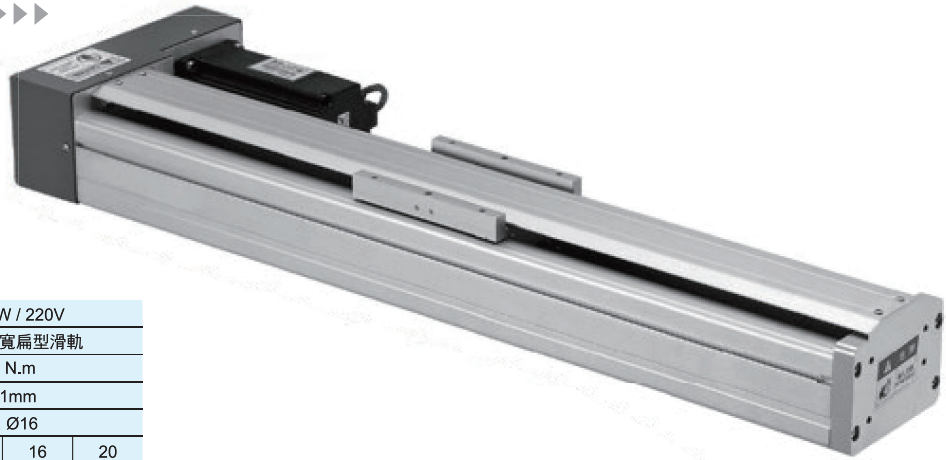

適用馬達	AC-200W / 220V				
滑軌與滑塊	MR15 WL 寬扁型滑軌				
額定扭矩	0.64 N.m				
重複精度	±0.01mm				
滾珠螺桿外徑 (mm)	Ø12, Ø16				
螺桿導程 (mm)	5	10	16	20	
最高速度 (mm/sec)	250	500	800	1000	
最大荷重 (kg)	水平	30	25	18	15
Max. Weight	垂直	17	12	10	8
光電開關	Model No. 674 x 3 pcs				
負載力矩表 N.m	Ma: 81 N.m				
	Mb: 35.2 N.m				
	Mc: 35.2 N.m				

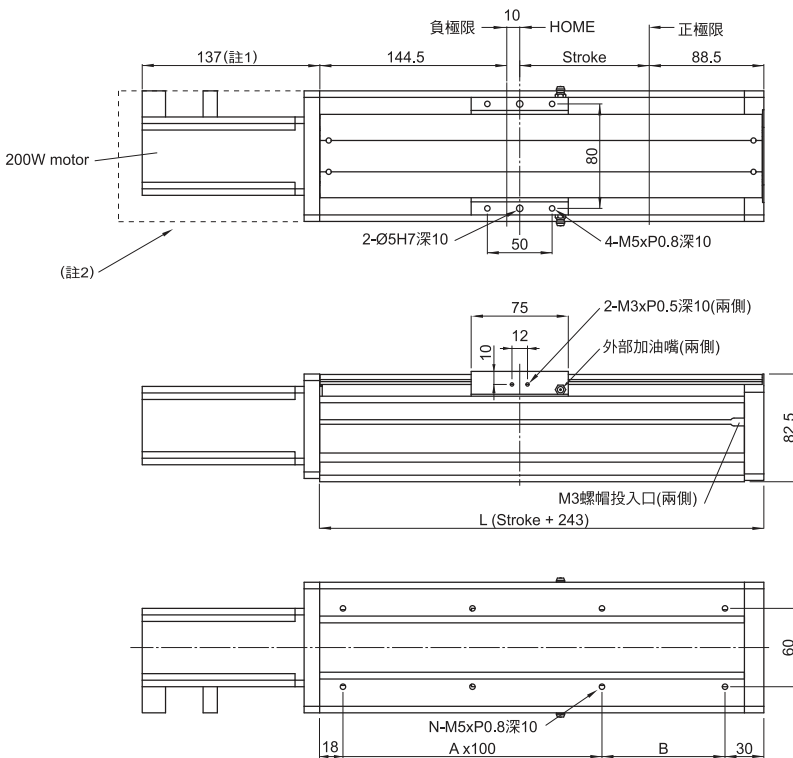

SAB100H直接式規格表

- 註1: 長度依馬達不同而變更
- 註2: 馬達蓋為選配
- 註3: 外置SENSOR安裝
(可選擇R右側或L左側)

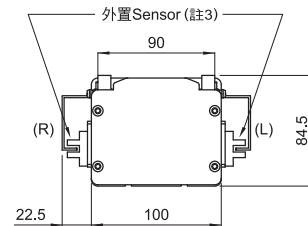

- SENSOR出線號數如下:
1. 正極限 +LS
 2. 原點 HOME
 3. 負極限 -LS

單位: mm

行程Stroke	50	100	150	200	250	300	350	400	450	500	550	600	650	700	750	800
L	293	343	393	443	493	543	593	643	693	743	793	843	893	943	993	1043
A	2	2	3	3	4	4	5	5	6	6	7	7	8	8	9	9
B	45	95	45	95	45	95	45	95	45	95	45	95	45	95	45	95
N	8	8	10	10	12	12	14	14	16	16	18	18	20	20	22	22
重量 Weight (kg)	5.0	5.6	6.2	6.8	7.4	8.0	8.6	9.2	9.8	10.4	11.0	11.6	12.2	12.8	13.4	14.0

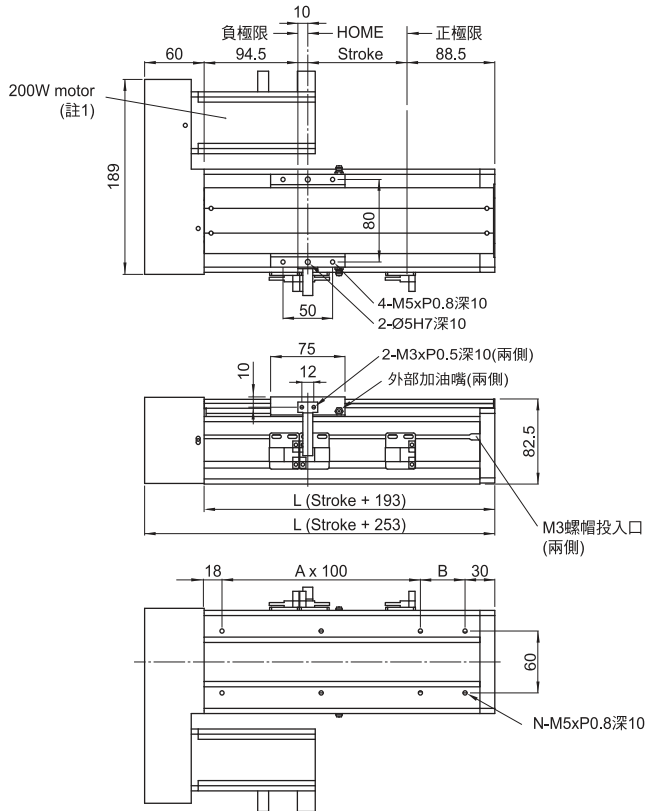

SAB 100H間接式規格表

註1: 搭配馬達為選配
 註2: 外置SENSOR安裝R右側

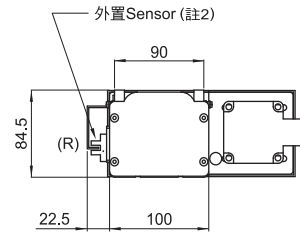

SENSOR出線號數如下:
 1. 正極限 +LS
 2. 原點 HOME
 3. 負極限 -LS

單位: mm

行程Stroke	50	100	150	200	250	300	350	400	450	500	550	600	650	700	750	800
S	303	353	403	453	503	553	603	653	703	753	803	853	903	953	1003	1053
L	243	293	343	393	443	493	543	593	643	693	743	793	843	893	943	993
A	1	2	2	3	3	4	4	5	5	6	6	7	7	8	8	9
B	95	45	95	45	95	45	95	45	95	45	95	45	95	45	95	45
N	6	8	8	10	10	12	12	14	14	16	16	18	18	20	20	22
重量 Weight (kg)	5.2	5.8	6.4	7.0	7.6	8.2	8.8	9.4	10.0	10.6	11.2	11.8	12.4	13.0	13.6	14.2

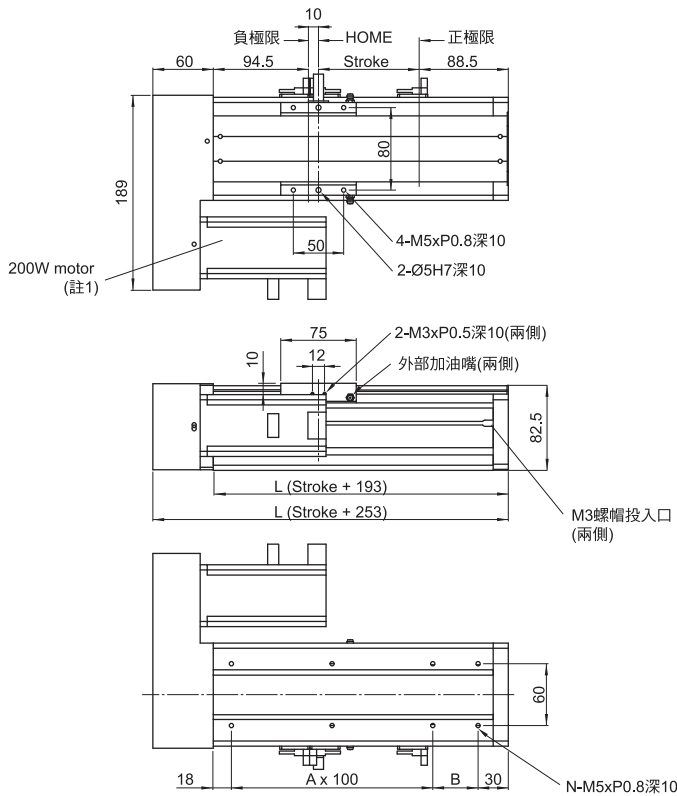

SAB 100H間接式規格表

註1: 搭配馬達為選配
 註2: 外置SENSOR安裝L左側

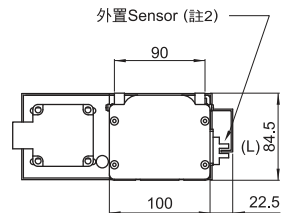

SENSOR出線號數如下:
 1. 正極限 +LS
 2. 原點 HOME
 3. 負極限 -LS

單位: mm

行程Stroke	50	100	150	200	250	300	350	400	450	500	550	600	650	700	750	800
S	303	353	403	453	503	553	603	653	703	753	803	853	903	953	1003	1053
L	243	293	343	393	443	493	543	593	643	693	743	793	843	893	943	993
A	1	2	2	3	3	4	4	5	5	6	6	7	7	8	8	9
B	95	45	95	45	95	45	95	45	95	45	95	45	95	45	95	45
N	6	8	8	10	10	12	12	14	14	16	16	18	18	20	20	22
重量 Weight (kg)	5.2	5.8	6.4	7.0	7.6	8.2	8.8	9.4	10.0	10.6	11.2	11.8	12.4	13.0	13.6	14.2